

AQUEA

MAIN DRAIN INSTALLATION INSTRUCTIONS (PART NO. 474-202)

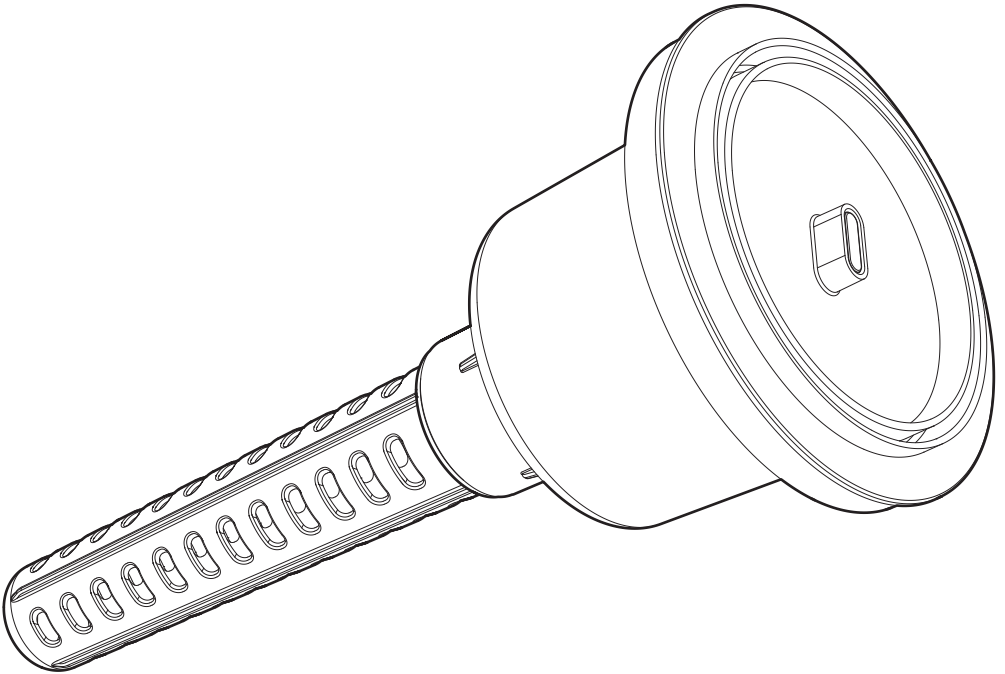

⚠ NOTE:

1. READ THIS DOCUMENT PRIOR TO INSTALLATION. IMPROPER INSTALLATION WILL VOID WARRANTY.
2. PRODUCT ONLY TO BE INSTALLED & SERVICED BY A SUITABLY QUALIFIED PROFESSIONAL.
3. NICHE COMPONENTS OF THIS PRODUCT ARE MANUFACTURED FROM ABS. SOME PVC JOINTING COMPOUNDS ARE NOT COMPATIBLE WITH ABS POSSIBLY RESULTING IN PRODUCT FAILURE. CHECK JOINTING COMPOUND COMPATIBILITY BEFORE USE.
4. INSTALLER TO ENSURE INSTALLATION MEETS ALL APPLICABLE ENGINEERING & REGULATORY REQUIREMENTS.
5. HYDROSTATIC VALVE IS A REPLACEABLE COMPONENT AND MUST NOT BE GLUED INTO NICHE.
6. THIS MANUAL CONTAINS IMPORTANT INFORMATION. ONCE INSTALLATION IS COMPLETE INSTALLER MUST PROVIDE THIS MANUAL TO OWNER/OPERATOR TO STORE IN A SAFE PLACE.

IMPORTANT

THIS PRODUCT IS NOT APPROVED
FOR USE AS A SUCTION OUTLET.

DO NOT CONNECT TO POOL
RECIRCULATION SYSTEM.

Ref: 474-808-09

Registered Design. Specifications subject to change without notice.

AQUEA™ is a trademark of Vantage Products Pty. Ltd.

The contents of this manual are the exclusive copyright of AQUEA™ and may not be reproduced without written permission. © 2019

Whilst every care was taken in preparation of this document, AQUEA™ accepts no responsibility for the accuracy of the information supplied.

PARTS SUMMARY

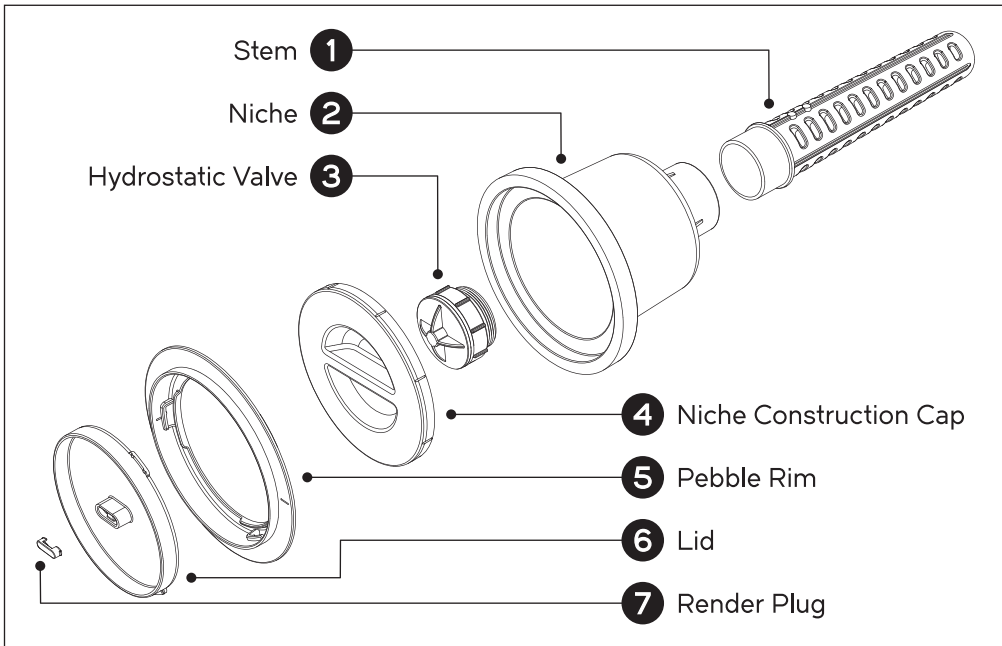

TYPICAL INSTALLATION

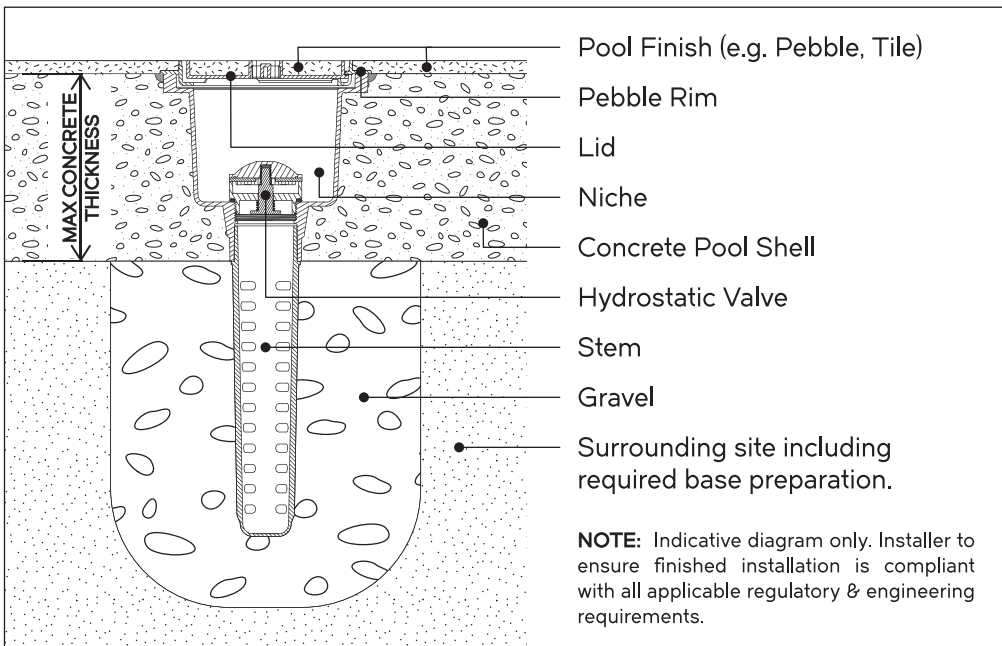

INSTALLATION INSTRUCTIONS

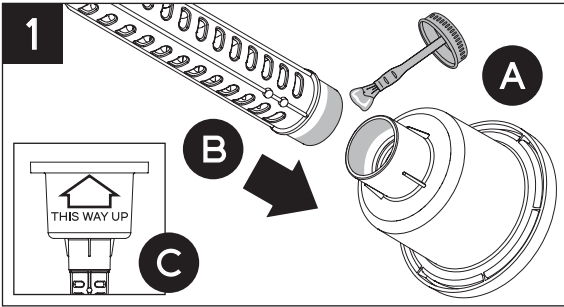

To assemble Stem into Niche:

- Remove contents from Niche.
- In a well ventilated area, apply a small amount of ABS-compatible solvent cement to Niche socket & top of Stem as shown (A). **ENSURE THREAD IN NICHE REMAINS FREE OF CEMENT.**
- Insert Stem into Niche socket until top of Stem is fully engaged (B).
- Hold upright (C) while cement cures to avoid any excess cement entering Niche.

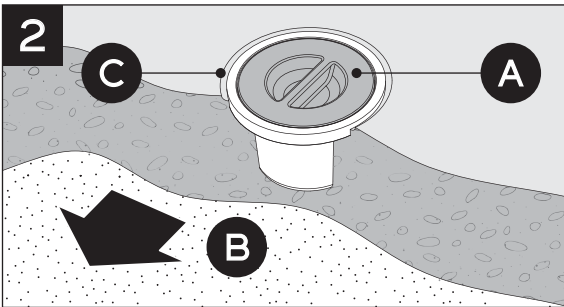

To install Niche into pool shell:

- Insert Construction Cap into Niche (A) & secure in desired location.
- Pour concrete minimising voids around Niche while keeping Stem clear of debris (B). Finished concrete surface must be level with front face of Niche.
- Create finger-tip size channel around Niche (C). Apply epoxy sealant after concrete has cured.

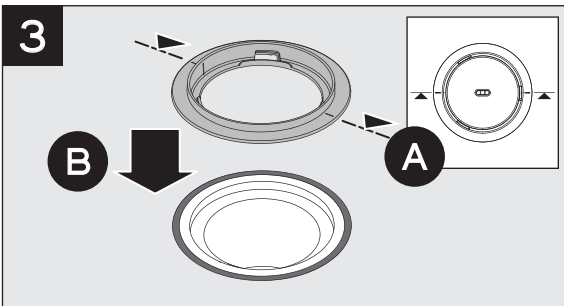

To install Pebble Rim:

- Remove Construction Cap from Niche.
- Use Pebble Rim's alignment marks to set-up desired orientation for Lid's central opening within pool (A).
- Insert Pebble Rim into Niche (B). Outer flange should rest evenly on finished concrete surface.

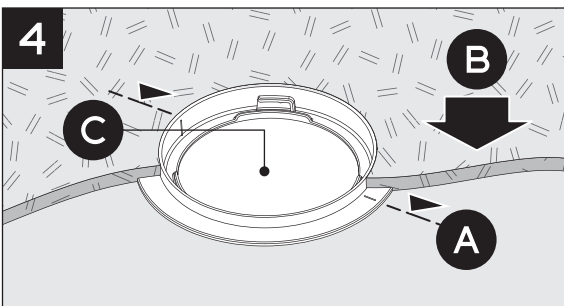

Applying pool finish:

- Re-check alignment of Pebble Rim and adjust if required (A).
- Apply pool finish to concrete surface, ensuring finish is level with top edge of Pebble Rim (B).
- Ensure Niche and Stem remain clear of any debris during finishing process (C).

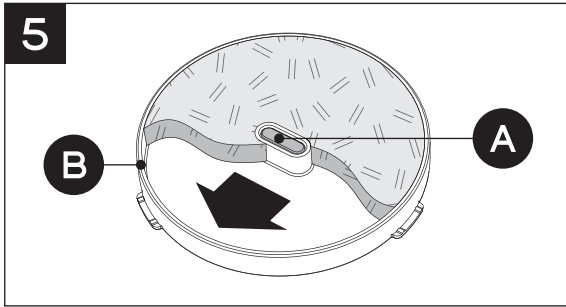

Applying pool finish to lid:

REMOVE LID FROM NICHE BEFORE APPLYING FINISH.

- Ensure Render Plug is inserted into central opening in Lid (A).
- Apply pool finish to Lid recess ensuring finished surface is flat & level with outer rim (B).
- Place lid on a level surface and allow pool finish to fully cure as per manufacturers' instructions.

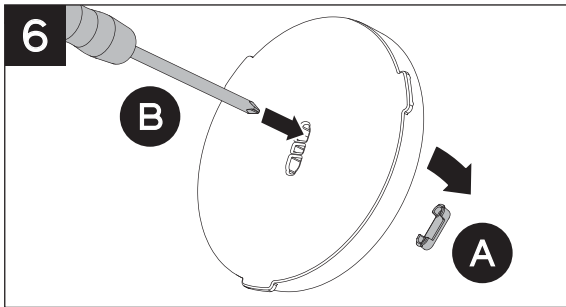

To remove Render Plug:

- Once pool finish is fully cured, remove Render Plug (A) by inserting screwdriver (B) or similar tool into Lid's rear openings.

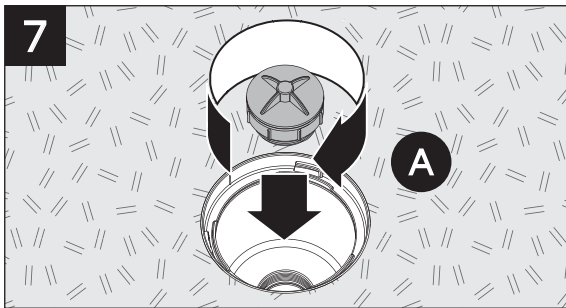

To install Hydrostatic Valve:

- Ensure Niche & Stem are clean and free from concrete, dust, dirt and any other debris.
- Screw Hydrostatic valve into Niche socket by **hand only** (A). Ensure valve is sufficiently tightened to provide a complete o-ring seal on floor of Niche. **DO NOT OVER-TIGHTEN VALVE AS THIS MAY RESULT IN DAMAGE TO VALVE OR NICHE.**

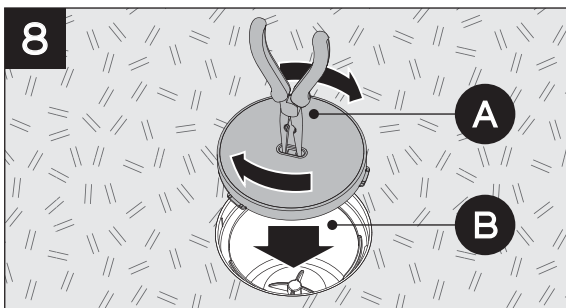

To assemble Lid:

- Insert narrow-nose pliers or similar tool into Lid's central openings (A).
- Insert Lid into Pebble Rim and rotate clockwise until Lid 'clicks' into place (B).

GENERAL MAINTENANCE

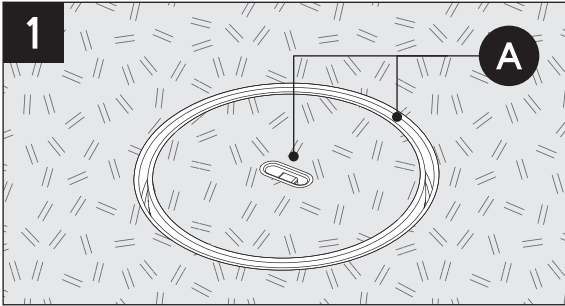

Ensure outer rim slot and central opening of Lid (A) remain free of any blockages, dirt and other debris.

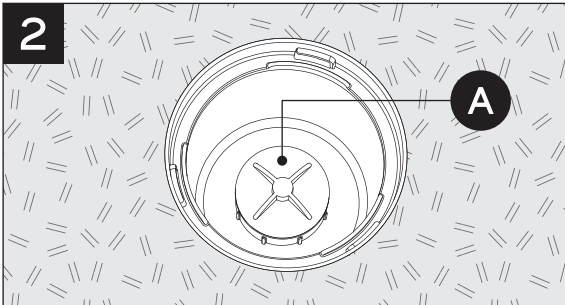

Ensure Hydrostatic Valve (A) is checked/serviced for correct operation and condition at least every 12 months by a qualified pool professional. Replace if necessary.

FEEDBACK & SUGGESTIONS

We are continually looking for ways to improve and expand our product range. Please contact us at hello@aquea.com.au if you have any feedback or suggestions!

WARRANTY POLICY

AQUEA (a division of Vantage Products Pty. Ltd.) warrants that, subject to the exclusions and limitations below, its products will be free from defects in materials and workmanship for a minimum period of 12 MONTHS from the date of purchase. All warranty periods commence on the date of purchase by the customer and are only valid in original country of purchase. The provisions of this warranty are not transferable.

If a defect appears in any Product supplied by AQUEA before the end of the Warranty Period due solely to defective materials or workmanship, AQUEA will in its sole discretion, and subject to these terms and conditions, either:

- a) repair the Product or the defective part of the Product free of charge; or
- b) have the Product or the defective part of the Product repaired by a qualified repairer free of charge; or
- c) replace the Product.

AQUEA at its sole discretion may replace defective parts of the Products with parts and components of similar quality, grade and composition where an identical part or component is not available. Refurbished parts may be used to repair the Products.

All repairs are to be carried out by AQUEA or its authorised repairer only. This warranty does not cover any costs related to travel, removal or re-installation associated with repair or replacement of the Product.

TO MAKE A WARRANTY CLAIM

To claim under this warranty the customer should immediately cease use of the Product once alleged defect is identified, and contact AQUEA within 30 days.

To make a claim the customer must:

1. Provide the following information:

- (a) proof of purchase disclosing date and place of purchase;
- (b) full details of the alleged defect; and
- (c) any other appropriate documentation.

2. The customer must make the Product or site available to AQUEA or its authorised repair agent for inspection and testing. If such inspection and testing finds no defect in the Product, the customer must pay AQUEA's usual costs of service work and testing.

3. The customer agrees to pay AQUEA's usual charges (including any service fee) for any goods or services provided by AQUEA not covered by this product warranty.

4. The customer is responsible for the cost of transport and all insurance of the Product to and from AQUEA or its authorised repair agent.

WARRANTY CONDITIONS

This warranty only applies where the following conditions are met:

1. The customer complies with the following general maintenance requirements:

- (a) The Product is maintained free from general debris or foreign matter.
- (b) The Product is maintained and serviced regularly (at least every 12 months) by a suitably qualified professional.
- (c) Where applicable, the Product is replaced at specified intervals as outlined in product literature by AQUEA.

2. Where applicable, Product has been used in pool or spa water which:

- (a) is maintained within a pH range of 7.2-7.6, and chemically balanced as per accepted industry standards.
- (b) is regularly (at least once a month) treated with a sanitising system in compliance with applicable regulatory recommendations or regulations.
- (c) has not exceeded 40 degrees Celsius in temperature.
- (d) has not been exposed to freezing conditions.

WARRANTY EXCLUSIONS

This warranty will not apply where:

- (a) the Product has not been installed in accordance with the installation instructions provided with the Product, any statutory requirements and these terms and conditions;
- (b) the Product has not been installed by a suitably qualified professional trained in the installation and operation of such products with more than 12 months industry experience;
- (c) a failure to observe and comply with the instructions supplied with product for the proper use, service or maintenance of the Product has occurred;
- (d) the Product has been used for a purpose other than that for which it was designed and manufactured;
- (e) removal or installation of the Product has contributed to, or resulted in, the defect or damage;
- (f) the Product has been repaired, altered or modified by someone other than AQUEA or its authorised agent;
- (g) substitute or replacement parts not provided by AQUEA have been used;
- (h) the defect has arisen due to abuse, misuse, neglect, or accident;
- (i) the Product has been subject to abnormal conditions, including environment, temperature, water, fire or other acts of nature;
- (j) the Product has been subject to abnormal corrosive conditions or abrasive chemicals;
- (k) the defect is the result of corrosion or normal wear and tear;
- (l) the defect is the result of insect and/or vermin infestation;
- (m) concrete, cement, render, pebbles or other pool surface finishes contribute to the defect, or inhibit proper function of the Product;
- (n) the damage occurred in transit;
- (o) after testing and inspection AQUEA cannot establish any fault in the Product;
- (p) the Product has been used in a commercial application;
- (q) the Product has not been supplied by AQUEA;
- (r) the defect is related to any cause other than a defect in the materials or workmanship of the Product.

LIMITATIONS

AQUEA makes no express warranties or representations other than set out in this warranty.

Except to the extent required by the Australian Consumer Law, the repair or replacement of the Product or part of the Product is the absolute limit of AQUEA's liability under this express warranty.

To the extent permitted by law, AQUEA will not be liable for:

- (a) Damage to any other property caused by defect in the Product.
- (b) Any indirect, special or consequential loss arising from or related to defects in the Product, including, but not limited to, loss of time, loss of use of the product, loss of business opportunity, loss of profits, loss of revenue, loss of goodwill, or inconvenience.
- (c) Any other damage as a result of weather or natural disaster.
- (d) Any claim against the customer by other parties.

Our goods come with guarantees that cannot be excluded under the Australian Consumer Law. You are entitled to a replacement or refund for a major failure and for compensation for any other reasonably foreseeable loss or damage. You are also entitled to have the goods repaired or replaced if the goods fail to be of acceptable quality and the failure does not amount to a major failure.

The benefits of this warranty are in addition to any rights and remedies imposed by Australian State and Federal legislation that cannot be excluded. Nothing in this warranty is to be interpreted as excluding, restricting or modifying any State or Federal legislation applicable to the supply of goods and services which cannot be excluded, restricted or modified.

CONTACT

For warranty claims visit www.aquea.com.au or contact AQUEA using details overleaf.

(Policy Revision 03)

AQUEA

WWW.AQUEA.COM.AU

AQUEA™ (a division of Vantage Products Pty. Ltd.)

17 DIANA DRIVE, BLACKBURN NORTH, VICTORIA 3130.

WARRANTY SUPPORT - WARRANTY@AQUEA.COM.AU

TECHNICAL SUPPORT - HELP@AQUEA.COM.AU

SALES ENQUIRIES - HELLO@AQUEA.COM.AU

PHONE - 0481 875 870