



Ultra Series

High Performance Single Speed Pump Range



LEGEND 
pumps

**BEST QUALITY!
BEST SERVICE!**

Pool products you can rely on

PERFORMANCE OF A LIFETIME

Power your system with the energy efficient Ultra Series pump from Legend. These super efficient pumps are built to last and engineered to perform even under the most demanding conditions.

Convenient features include a see-through cover so pool owners know exactly when to empty the extra large debris basket and a housing design that makes it as quiet as it is dependable.



Empowered by
LEGEND 

www.legendproducts.com.au

Ultra Series



FEATURES & BENEFITS

- **HEAVY DUTY, HIGH PERFORMANCE MOTOR**
With advanced airflow ventilation for quieter, cooler operation.
- **HIGH QUALITY**
Industrial-Size Carbon Ceramic Mechanical Seal.
- **FULL FLOW HYDRAULICS**
Allows a greater flow at a lower operation cost
- **SIMPLE ACCESS**
Motor and entire drive group assembly can be removed, without disturbing pipe or mounting connections by disengaging just six bolts.
- **DOUBLE INSULATED WATER CIRCUIT**
- **IMPRESSIVE LEAF HOLDING CAPACITY**
Rigid construction includes load-extender ribbing for free flowing operation, even under extra-heavy debris loads.
- **SELF-PRIMING**
Suction lift up to 1.8m above water level without a check valve.
- **SEE THROUGH STRAINER COVER**
Lexan cover lets you see when basket needs cleaning and eliminates guesswork. This basket has a rigid construction including load-exterior ribbing for free flowing operation.
- **UNI-BRACKET MOUNTING**
Provides stable, stress-free support, plus versatility for any installation requirement.

CHARTED PERFORMANCE CURVE- FLOW (LPM) VS HEAD LOSS (M):

MODEL	6M	8M	10M	12M	15M	18M	20M
Ultra 230	260	230	192	150	60		
Ultra 320	368	320	290	245	140		
Ultra 350	400	360	330	280	200		
Ultra 430	475	435	390	340	240		
Ultra 530		530	480	430	350	245	135

Typical installation for in ground pools-use 8M only as a guide. All dimensions listed without barrel unions fitted.

ULTRA SERIES PUMP PERFORMANCE

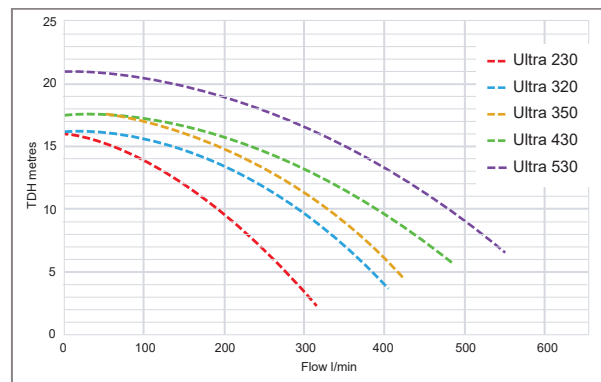

SPECIFICATIONS

MODEL	INGRESS PROTECTION	INPUT POWER (KW)	INPUT AMPS	HP	LXW (MM)	PVC PIPE (MM)	NOISE DB(A)@1M	WEIGHT (KG)
Ultra 230	IPX5	0.74	3.3	0.75	569 X 240	40/50	< 70	12.5
Ultra 320	IPX5	0.98	4.34	1	569 X 240	40/50	< 70	13.4
Ultra 350	IPX5	1.1	5.1	1.25	594 X 240	40/50	< 70	15.3
Ultra 430	IPX5	1.38	6.23	1.5	594 X 240	40/50	< 70	15.3
Ultra 530	IPX5	1.86	8.33	2	618 X 240	40/50	< 70	19.05

Typical installation for in ground pools-use 8M only as a guide. All dimensions listed without barrel unions fitted.

DIMENSIONAL DRAWINGS

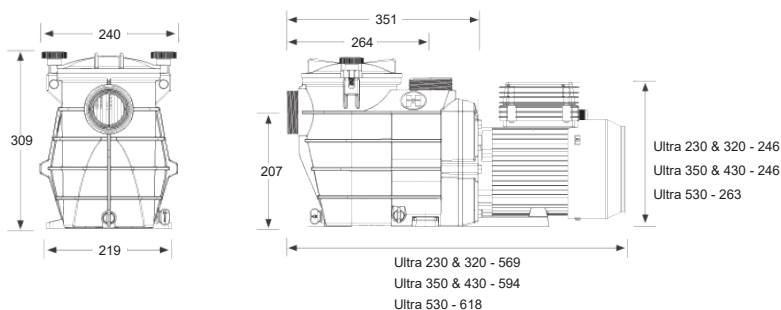

WARRANTY

- 1 year in field warranty
- 3-year warranty on motor and wet end
- 12 months on mechanical seal

Legend Products and Services

23 Dulwich Street, Loganholme, Brisbane, QLD, 4129.

Phone: 07 3806 1823

Email: sales@legendproducts.com.au