

INSTALLATION AND OPERATION MANUAL

Introduction

The Poolrite C Series range of cartridge filters have been developed together with leading swimming pool and spa professionals. The result is a filter which gives many years of trouble free performance with high quality water filtration.

The polyester filter elements offers fine grade filtration and enables longer filtration cycles due to the compact design of the cartridge element pleats.

Swimming pool and spa water is pumped through the polyester filter element where suspended particles are trapped, resulting in sparkling clear water returning to your swimming pool and spa.

Exploded Diagram

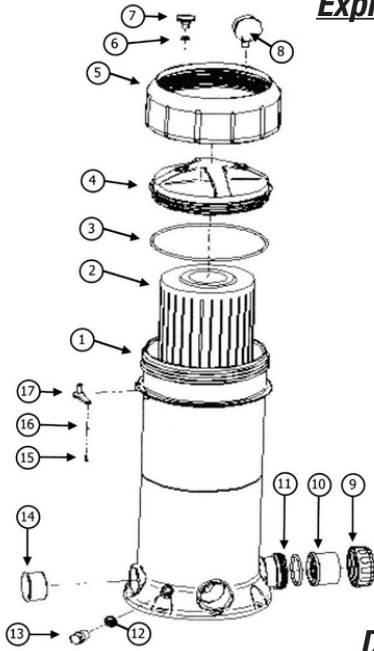

Item	Title	Quantity
1	Tank Base	1
2	Element	1
3	Lid O Ring	1
4	Lid	1
5	Lock Ring	1
6	Air Bleed O Ring	1
7	Air Bleed	1
8	Pressure Gauge	1
9	Mac Union Nut	1
10	Mac Union Tail	2
11	Mac Union O Ring	2
12	Drain Bung O Ring	1
13	Drain Bung	1
14	Blank Cap	1
15	Safety Lock Lever Screw	1
16	Safety Lock Lever Washer	1
17	Safety Lock	1

Dimensions

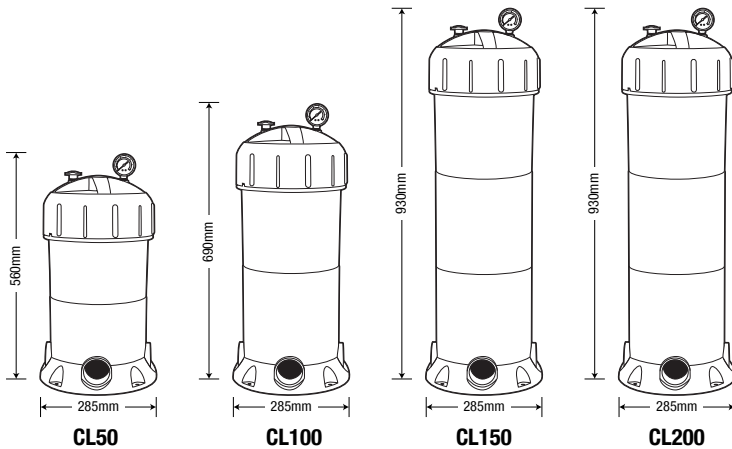

Warranty

The Poolrite C Series Cartridge Filters are warranted for a period of 5 years (excluding cartridge element).
For full details on warranty conditions, please visit www.poolrite.com.

Installation

Filter Site and Location

C Series Cartridge Filters must be installed to the following requirements:

- A level concrete slab or similar flat and stable site.
- Plumbed as close as practicable to swimming pool or spa using 40mm or 50mm pipe. For lengths over 15 metres, pipe of 50mm is recommended.
- For cleaning, sufficient clearance height must allow for removal of cartridge filter, lock ring, lid and filter element. Refer to 'Filter Element Cleaning Procedure' section.
- Sufficient space allowed around cartridge filter and attached plumbing for routine maintenance and cleaning.
- Drainage for any water that could accumulate around the filter and any electrical components is essential.
- For weather protection the C Series Cartridge Filter is constructed of corrosion resistant materials, however, it is recommended that the entire filtration system be adequately protected from the weather.

Filter Positioning

For installations where the filter is below the water level of the swimming pool or spa, isolating valves should be fitted either side of the filter to aid cleaning and maintenance.

The C Series Cartridge Filter has two inlet and outlets but only one of each is used.

When choosing inlet and outlet ports consideration should be given to the suction line and return line positions. This will leave two vacant ports to which the blank caps provided must be fitted.

Use the mac unions for the inlet and outlet ports ensuring the o-rings are correctly seated.

Ensure mac unions are hand tight only.

Filter Operation

- Ensure pump is primed.
- Ensure isolating valves, where fitted, are open.
- Turn pump on.
- Observe the "clean filter" running pressure, take note and record this pressure. The "clean filter" pressure will vary due to pump and pipe size, distance and plumbing configuration.
- Filter cycles - the filter operation time will vary depending on swimming pool or spa design, size, heating requirements etc. Consult your pool builder or supplier.
- The polyester filter element will require cleaning when the pressure gauge reading is between 40Kpa - 60 Kpa above the "clean filter" running pressure, as mentioned above.

Filter Element Cleaning Procedure

- Turn pump off.
- Close isolating valves, where fitted.
- Open air bleed on filter lid.
- Push lid down firmly to release friction with lock ring.
- Depress safety lock lever and unscrew lock ring.
- Remove lid.
- Lift out element and hose down with good pressure from garden hose or soak cartridge in suitable de-greaser or cartridge agent recommended by your filter supplier.
- Replace filter element.
- Clean and lubricate lid o-ring with o-ring lubricant. Fit o-ring into seat on lid and push lid down firmly on cartridge filter.
- J screw lock ring down fully, stopping when safety lock lever fits correctly into recess.
- Close air bleed valve on lid.
- Open isolating valves, where fitted.

Specifications

MODEL	CL50	CL100	CL150	CL200
Max Flow Rate (L/min)	325	370	470	470
Minimum Element Removal Height	870mm	1075mm	1564mm	1564mm
Recommended Pump Model	EP-550 0.75 hp	SQI-400 / EP-750 / SQ Gemini 1.0 hp	SQI-500 / EP-930 1.25 hp	SQI-600 / SQI-700 / EP-1100 1.5-2.0 hp
Maximum Working Pressure	280 kPa	280 kPa	280 kPa	280 kPa

Troubleshooting

Low Flow:	Clogged polyester element. Refer to filter element cleaning procedure.
	Blockage or restriction in pump or plumbing lines.
Lock Ring won't unscrew:	Push lid firmly to release friction with lock ring.
	Safety lever not depressed.
Lid Jammed:	Check air bleed is open on filter lid.
Debris Returning to Swimming Pool or Spa:	Check condition of polyester cartridge element. Replace if split or polyester pleats or moulded ends of cartridge filter are damaged.



Marco Engineering Pty. Ltd.

P 07 3803 6222 | F 07 3803 6353 | E poolrite@evolvegrp.com

PO Box 1491, Browns Plains, QLD 4118, AUSTRALIA

www.poolrite.com

