



HAYWARD®

SUPER II® ECO

>>> SINGLE SPEED PUMP

HIGH-PERFORMANCE PUMP SERIES

PERFORMANCE OF A LIFETIME

Power your system with the energy efficient, Super II Eco pump series from Hayward. These super efficient pumps are built to last and engineered to perform even under the most demanding conditions.

Convenient features include a see-through cover so pool owners know exactly when to empty the extra large debris basket and a housing design that makes it as quiet as it is dependable.



FEATURES & BENEFITS

> **See through the strainer cover** Lexan cover lets you see when basket needs cleaning and eliminates guesswork. This basket has a rigid construction including load-exterior ribbing for free flowing operation.

> **Full flow Hydraulics** allow a greater flow at a lower operation cost.

> **Simple Access** to all internal parts. Motor and entire drive group assembly can be removed, without disturbing pipe or mounting connections by disengaging just six bolts.

> **Self-Priming** Suction lift up to 1.8m above water level without a check valve.

> **Super II Basket** is more like a bucket with impressive leaf holding capacity. Rigid construction includes load-extender ribbing for free flowing operation, even under extra-heavy debris loads.

> **Heavy Duty, High-Performance Motor** with an airflow ventilation for quieter, cooler operation.

> **High Quality** Industrial-Size Carbon Ceramic Mechanical Seal.

> **Uni-Bracket Mounting Base** provides stable, stress-free support, plus versatility for any installation requirement.

> **Double Insulated Water Circuit**

Performance Curve - Flow (lpm) vs Head Loss (m)

MODEL	6m	8m	10m	12m	15m	18m	20m	22m
SIIE 230	260	230	192	150	60			
SIIE 320	368	320	290	245	140			
SIIE 350	400	360	330	280	200			
SIIE 430	475	435	390	340	240			
SIIE 530		530	480	430	350	245	135	
SIIE 580		600	565	515	440	340	250	120

SUPER II ECO PUMP PERFORMANCE

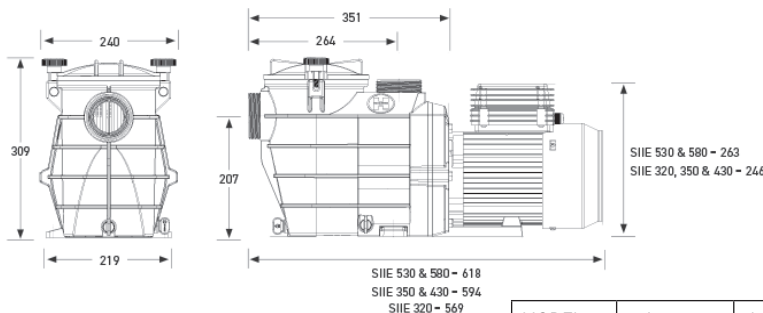
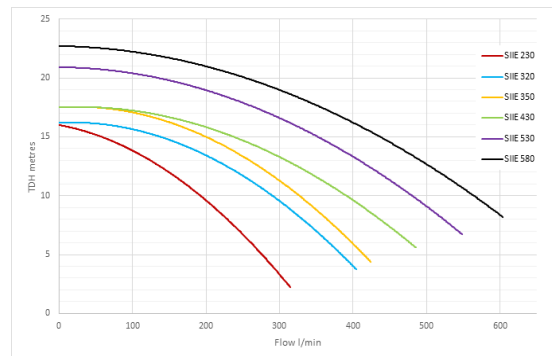

OVERALL DIMENSIONS

MODEL	Ingress protection	Input Power (kW)	Input Amp	HP	Length (mm)	Width (mm)	PVC Pipe (mm)	Noise dB(A)@1m	Weight (kg)
SIIE 230	IPX5	0.74	3.3	0.75	569	240	309	< 70	12.5
SIIE 320	IPX5	0.98	4.34	1	569	240	309	< 70	13.4
SIIE 350	IPX5	1.1	5.1	1.25	594	240	309	< 70	15.3
SIIE 430	IPX5	1.38	6.23	1.5	594	240	309	< 70	15.3
SIIE 530	IPX5	1.86	8.33	2	618	240	309	< 70	19.05
SIIE 580	IPX5	2.33	10.46	3	618	240	309	<70	20.8

Typical installation for in ground pools-use 8M only as a guide. All dimensions listed without barrel unions fitted.

>> www.hayward-pool.com.au >> 1300 POOLS1 >> sales@hayward-pool.com.au

Pumps >> **Filters** >> **Heating** >> **Cleaners** >> **Sanitisation** >> **Automation** >> **Lighting** >> **White Goods**



Hayward and Tristar are registered trademark of Hayward Industries, Inc. © 2019 Hayward Industries, Inc. All other trademarks not owned by Hayward are the property of their respective owners. Hayward is not in any way affiliated with or endorsed by those third parties.

