



Super 90 Series **LED** pumps

Designed to suit all domestic pools and spas



LEGEND 
pumps

**BEST QUALITY!
BEST SERVICE!**

Pool products you can rely on

- Flow Rates from 230 - 500 lpm
- Available in 1.0 to 2.0 HP
- German design & engineering
- Manufactured in Australia
- Quieter, smoother performance
- Non corrosive lid with large capacity basket
- Robust construction, highest quality material
- 5 Year Warranty*



Super 90 Series



The Legend Super 90 Series is the ideal choice for all domestic pool and spa applications including heating, salt chlorination and automatic pool cleaning.

Features:

- A high resistance to corrosion and salt water
- Maximum effectiveness at low power input
- Robust construction, highest quality material
- The ultimate in reliability
- No contact between motor and pump shaft with pool or spa water
- Highest quality mechanical seal
- Fan cooled - suitable for high ambient temperatures
- Closed impeller
- Stainless steel motor shaft
- Easy to remove clear strainer lid
- Every pump is factory wet tested for quality control

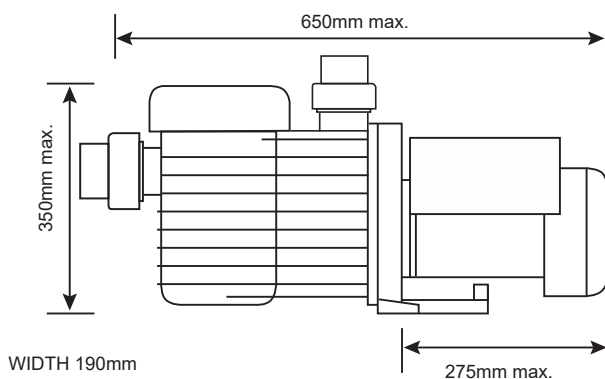
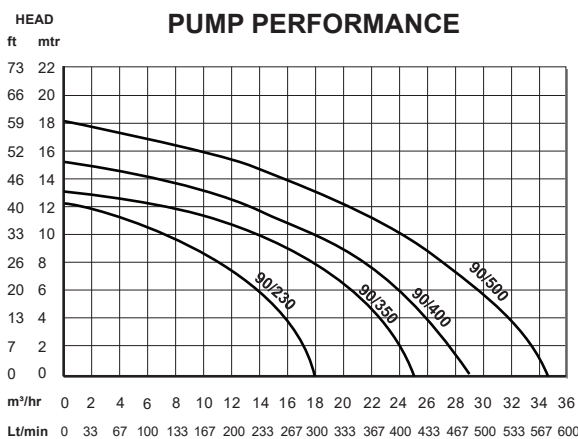

LEGEND LED Lid Light

See what's happening in your pool pump basket – even in the dark

- LED Brilliance
- Up to 5 year battery life
- Replaceable battery
- Larger basket collects more debris

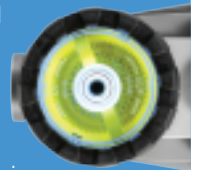

	90/230	90/350	90/400	90/500
Head Max/Min - m	12/4	13/4	15/4	18/4
Inlet Connection - mm	50	50	50	50
Outlet Connection - mm	40	40	40	40
Motor Speed - RPM	2850	2850	2850	2850
Power Input - V	240	240	240	240
Power Output - Kw	650	750	930	1100
AMPS	4.2	4.7	6.0	6.6
Weight - kg	11	13	15	19
MaxWaterTemp - Deg.C	40	40	40	40
HP	1.0	1.25	1.5	2.0

WARRANTY

* Five (5) Year Factory Warranty on the following wet end components: Casing, Diffuser, Gland Housing, Impeller and Mechanical Seal. Two (2) Year Warranty on motor and in all commercial applications. The pouring of salt and chemicals directly into the skimmer box will void full warranty. The pump pictured above can be used for pool water with a salt concentration of up to 0.5%, ie: 5000ppm. For higher salt concentrations, please contact us.

Legend Products and Services

23 Dulwich Street, Loganholme, Brisbane, QLD, 4129.

p: 07 3806 1823

e: sales@legendproducts.com.au